

**ENGLISH**

**Mammoth Stage 1 x 1 m / 2 x 1 m V2**

**Product code: 70610/70620**

**Table of contents**

---

**Warning** .....2  
Safety Instructions .....2  
Operating Determinations .....3  
Return Procedure .....3  
Claims.....3

**Description of the device**.....4  
Overview .....5

**Installation**.....6  
One Mammoth Stage.....6  
Mammoth Stage 1 x 1 m.....6  
Mammoth Stage 2 x 1 m.....6  
Multiple Mammoth Stages.....7  
Mammoth Stage Clamp Installation.....7  
Mammoth Stage Self-leveling Insert Installation .....8  
Installation Example .....9

**Examples**.....10  
12 m<sup>2</sup> Mammoth Stage.....10  
60 m<sup>2</sup> Mammoth Stage.....11

**Miscellaneous** .....12  
Total Height Information .....12  
Mammoth Stage (40 cm) .....12  
Mammoth Stage (60 cm).....12

**Maintenance** .....12

**Product Specifications**.....13

## Warning



**For your own safety, please read this user manual carefully  
before your initial start-up!**



## Unpacking Instructions

Immediately upon receiving this product, carefully unpack the carton and check the contents to ensure that all parts are present, and have been received in good condition. Notify the dealer immediately and retain packing material for inspection if any parts appear damaged from shipping or the carton itself shows signs of mishandling. Save the carton and all packing materials. In the event that a fixture must be returned to the factory, it is important that the fixture be returned in the original factory box and packing.

## Your shipment includes:

- Showgear Mammoth Stage 1 x 1 m / 2 x 1 m
- User manual

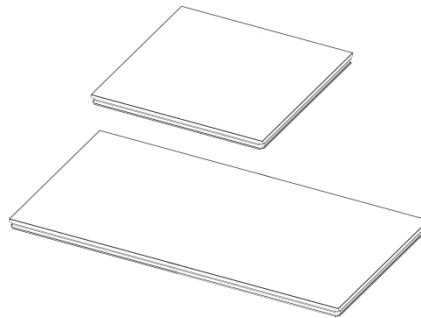

## Safety Instructions

Every person involved with the installation, operation and maintenance of this device has to:

- be qualified
- follow the instructions of this manual

Before assembly, please make sure that there is no damage caused by transportation. Should there be any, consult your dealer and do not use the device.

To maintain perfect condition and to ensure a safe usage, it is absolutely necessary for the user to follow the safety instructions and warning notes contained in this manual.

Please consider that damages caused by manual modifications to the device are not subject to warranty.

This device contains no user-serviceable parts. Refer servicing to qualified technicians only.

## IMPORTANT:

The manufacturer will not accept liability for any resulting damages caused by the non-observance of this manual or any unauthorized modification to the device.

- Never remove warning or informative labels from the unit.
- Avoid brute force when installing the device.
- Only use the device after having checked if all screws are tightly fastened.
- If your Showgear device fails to work properly, discontinue the use immediately. Pack the unit securely (preferably in the original packing material), and return it to your Showgear dealer for service.
- The user is responsible for correct positioning of the Mammoth Stage. The manufacturer will not accept liability for damages caused by the misuse or incorrect installation of this device.
- Repairs and servicing must be carried out by a qualified technician.
- WARRANTY: Till one year after date of purchase.

## Operating Determinations

- If this device is used in any other way than the one described in this manual, the product may suffer damages and the warranty becomes void.
- Any other operation may lead to dangers like crash, collapse etc.

*You endanger your own safety and the safety of others!*



## Return Procedure

Returned merchandise must be sent prepaid and in the original packing, call tags will not be issued. Package must be clearly labeled with a Return Authorization Number (RMA number). Products returned without an RMA number will be refused. Highlite will not accept the returned goods or any responsibility. Call Highlite 0031-455667723 or mail [aftersales@highlite.com](mailto:aftersales@highlite.com) and request an RMA prior to shipping the fixture. Be prepared to provide the model number, serial number and a brief description of the cause for the return. Be sure to properly pack fixture, any shipping damage resulting from inadequate packaging is the customer's responsibility. Highlite reserves the right to use its own discretion to repair or replace product(s). As a suggestion, proper UPS packing or double-boxing is always a safe method to use.

**Note: If you are given an RMA number, please include the following information on a piece of paper inside the box:**

- 01) Your name
- 02) Your address
- 03) Your phone number
- 04) A brief description of the symptoms

## Claims

The client has the obligation to check the delivered goods immediately upon delivery for any shortcomings and/or visible defects, or perform this check after our announcement that the goods are at their disposal. Damage incurred in shipping is the responsibility of the shipper; therefore the damage must be reported to the carrier upon receipt of merchandise.

It is the customer's responsibility to report and submit claims with the shipper in the event that a fixture is damaged due to shipping. Transportation damage has to be reported to us within one day after receipt of the delivery.

Any return shipment has to be made post-paid at all times. Return shipments must be accompanied with a letter defining the reason for return shipment. Non-prepaid return shipments will be refused, unless agreed otherwise in writing.

Complaints against us must be prepared in writing or sent by fax within 10 working days after receipt of the invoice. After this period complaints will not be handled anymore.

Complaints will only then be considered if the client has so far complied with all parts of the agreement, regardless of the agreement from which the obligation is resulting.

## Description of the device

### Features

The Mammoth Stage is a stage set featuring a non-slip surface structure. It is perfectly suitable for outdoor use.

Thanks to its efficient aluminum construction, the Mammoth Stage is extremely easy to set up and it complies with the most strict safety standards.

Apart from purchasing the two separate stage sets (**Mammoth Stage 1 x 1 m** and **Mammoth Stage 2 x 1 m**) it is also possible to combine two **Mammoth Stage 1 x 1 m** sets to create one 2 x 1 m set, as two or more 1 x 1 m stage decks can be attached to each other by means of the special clamp.

- Maximum load: 500 kg/m<sup>2</sup>
- Material: Aluminum (6063-T66)
- Dimensions: 1000 x 1000 x 55 mm (LxWxH) / 2000 x 1000 x 55 mm (LxWxH)
- Weight: 12 kg / 24 kg

### Mammoth Stage 1 x 1 m

[70610](#) – Mammoth Stage Deck 1 x 1 m

### Mammoth Stage 2 x 1 m

[70620](#) – Mammoth Stage Deck 2 x 1 m

### Mammoth Stage assembly

[70611](#) – Mammoth Legs 20 cm (1 x 1 m)

[70612](#) – Mammoth Legs 40 cm (1 x 1 m)

[70613](#) – Mammoth Legs 60 cm (1 x 1 m)

[70630](#) – Mammoth Stage Clamp

[70637](#) – Mammoth Stage Self-leveling Insert

### Mammoth Stage accessories

[70631](#) – Mammoth Guard Rail (1 m)

[70632](#) – Mammoth Guard Rail Clamp

[70633](#) – Mammoth Stairs 20+40 cm (2 steps)

[70634](#) – Mammoth Stairs 60 cm (1 step)

[70635](#) – Mammoth Stairs 80 cm (1 step)

[70638](#) – Mammoth Stage Assembly Insert

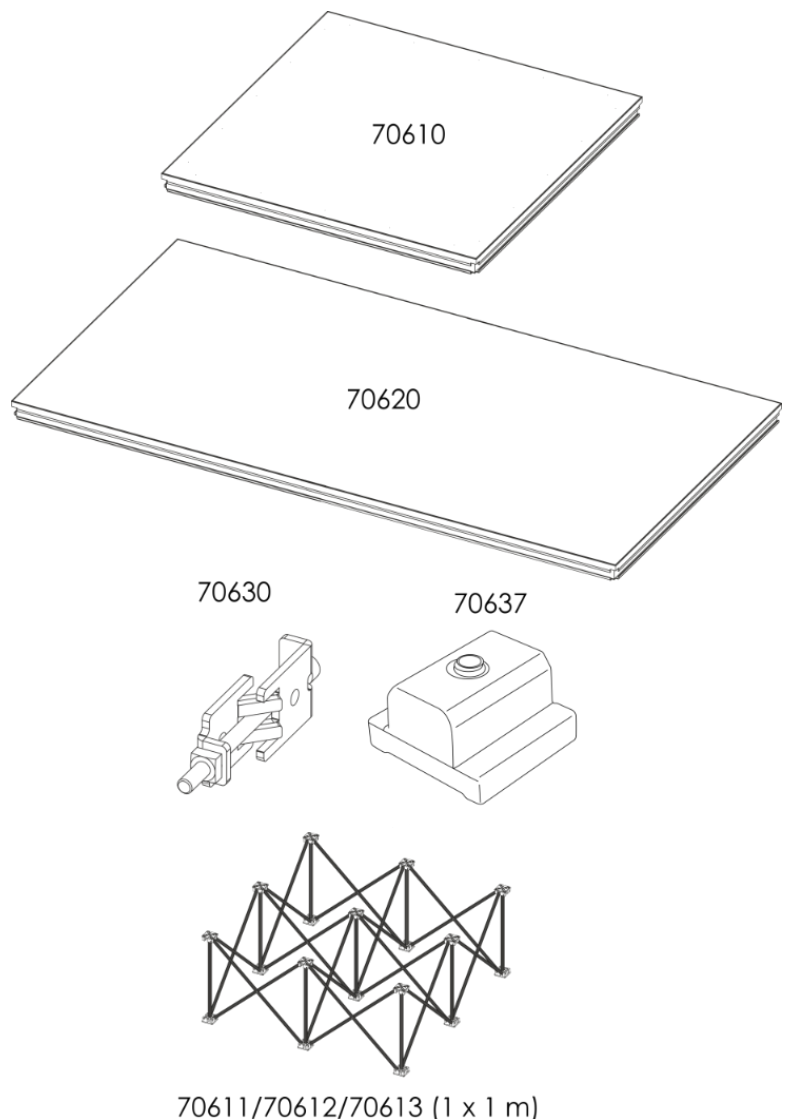

Overview

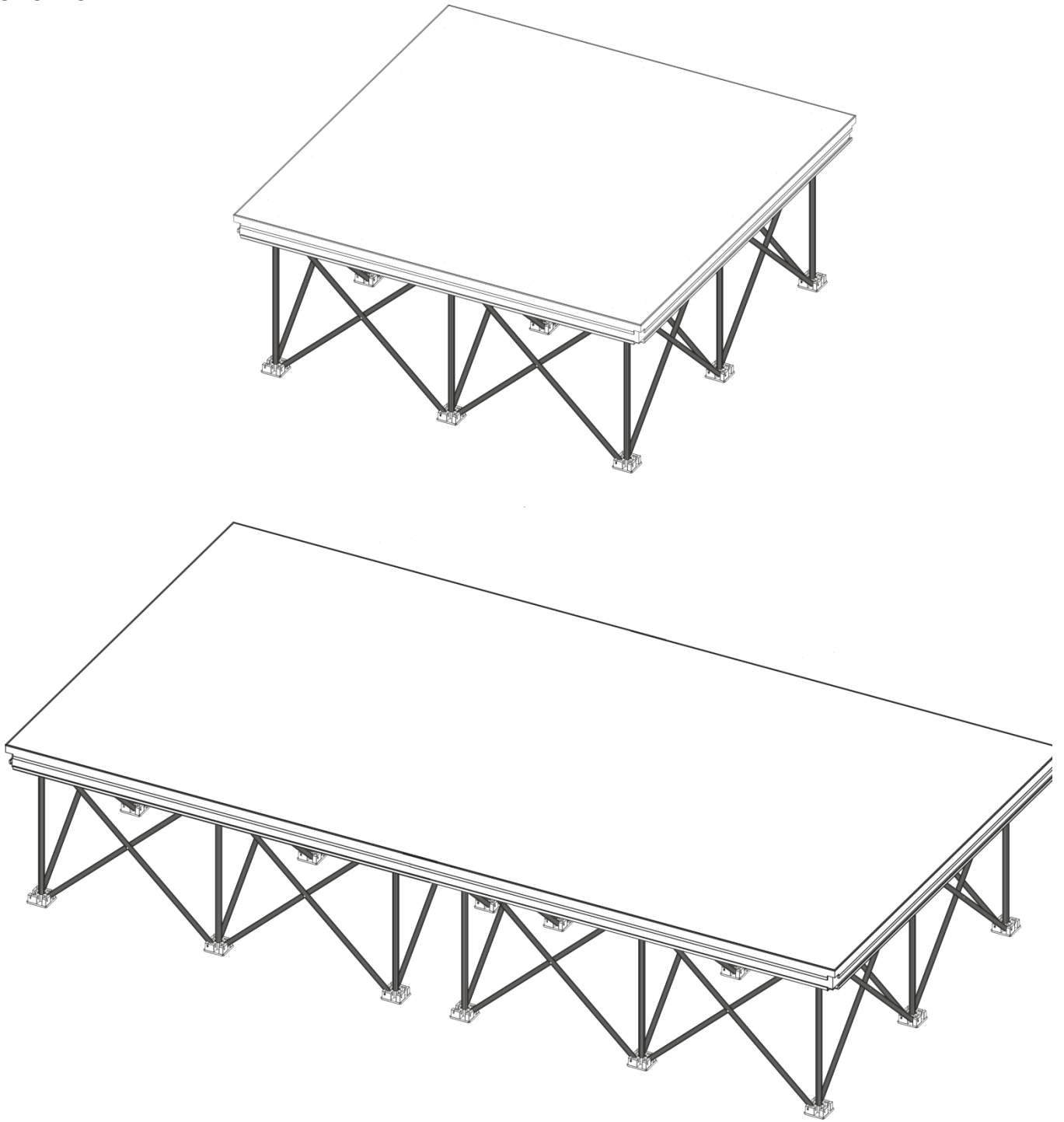

Fig. 01

## Installation

Remove all packing materials from the Mammoth Stage. Check if all foam and plastic padding is removed.

**Damages caused by non-observance are not subject to warranty.**

### One Mammoth Stage

- 01) Unpack the Mammoth Stage deck and the Mammoth legs.
- 02) Extend the Mammoth legs to about 80% of their maximum width.
- 03) Place the stage deck upon the Mammoth legs.
- 04) Completely extend the legs until they click into place.
- 05) Check whether all the elements are fitted properly.

#### Mammoth Stage 1 x 1 m

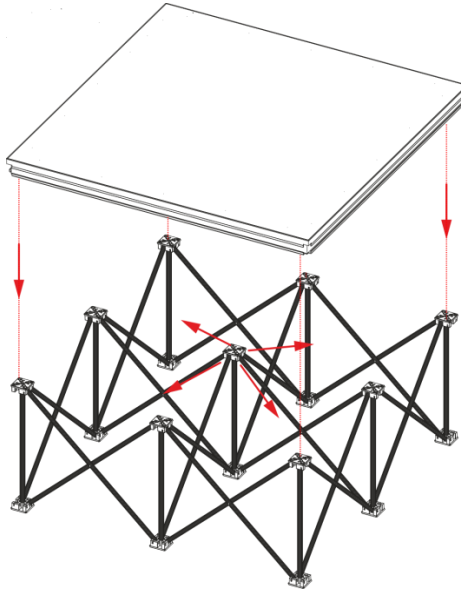

Fig. 02

#### Mammoth Stage 2 x 1 m

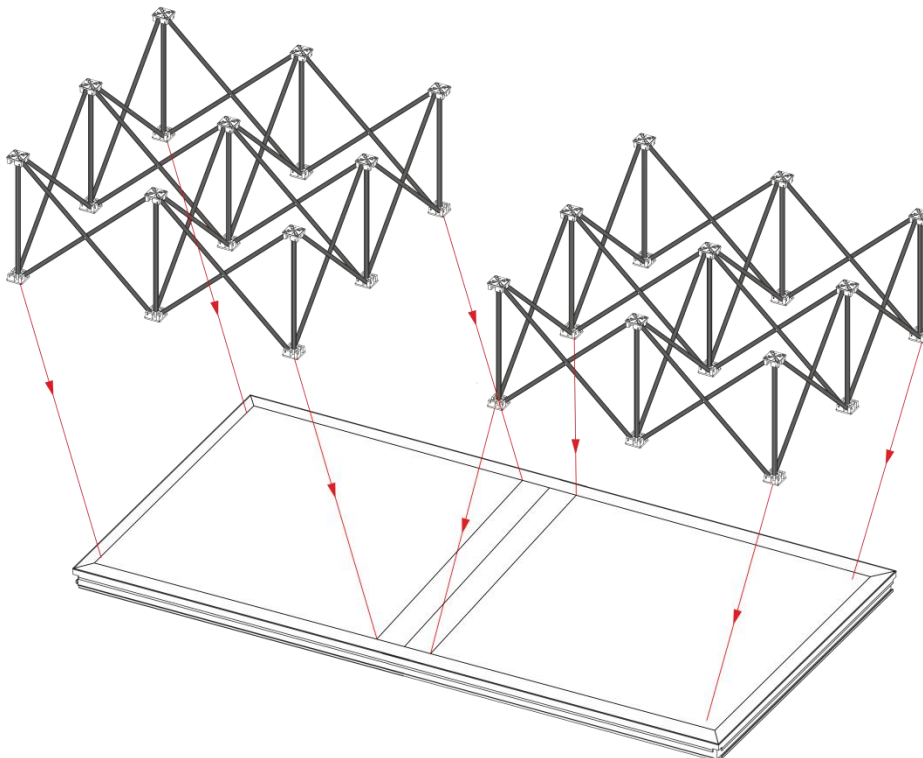

Fig. 03

## Multiple Mammoth Stages

In order to connect two Mammoth Stage decks, you can use the following clamp:

- 70630 – Mammoth Stage Clamp



Apart from the clamp, you can also use 70637 – Mammoth Stage Self-leveling Insert, for extra stability.



### Mammoth Stage Clamp Installation

- 01) Unpack two sets of the Mammoth Stage.
- 02) Assemble both sets.
- 03) Insert the Mammoth Stage clamp (70630) in between the two stage decks.
- 04) Connect both sets.

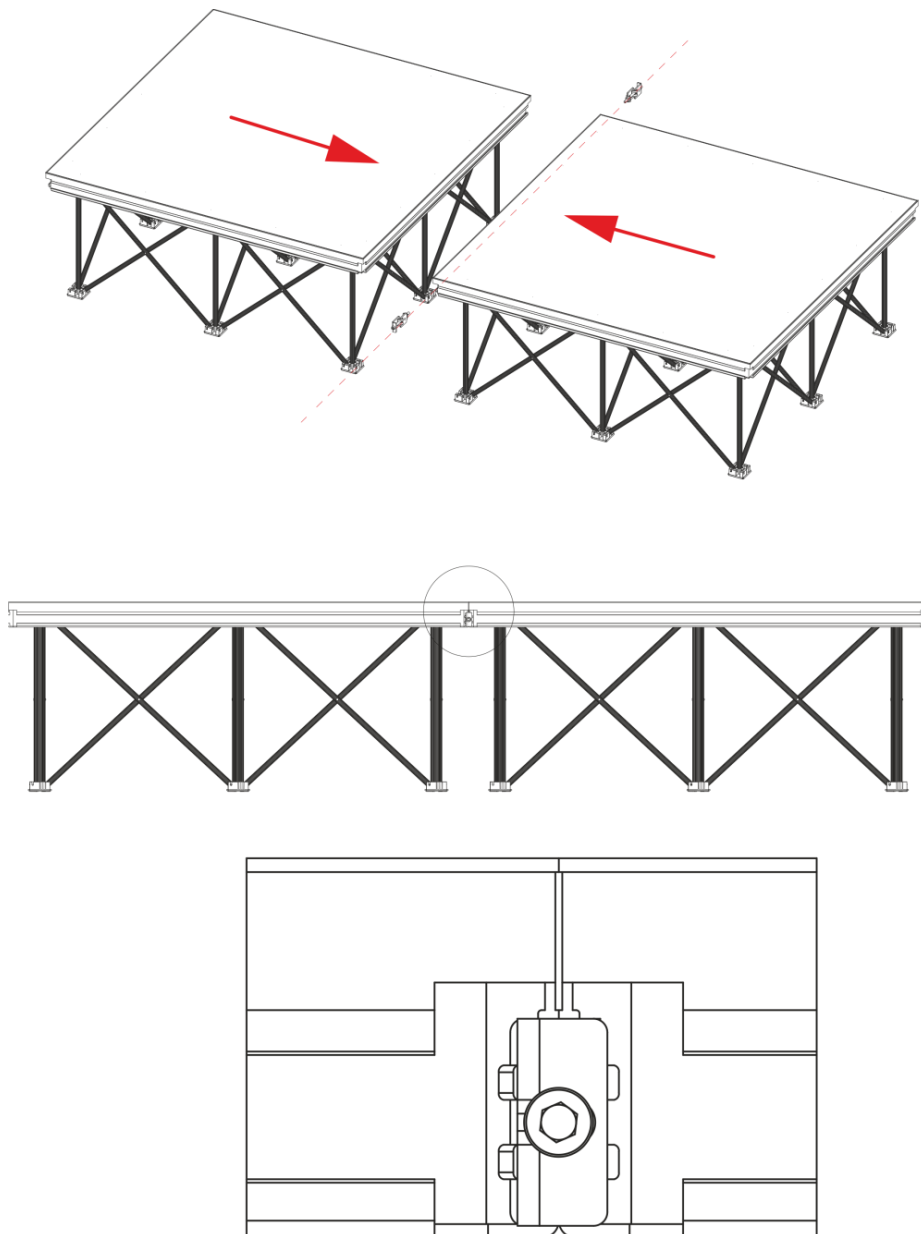

Fig. 04



**Mammoth Stage Self-leveling Insert Installation**

- 01) Unpack two sets of the Mammoth Stage.
- 02) In order to level the two sets, insert the Mammoth Stage Self-leveling Insert (**70637**) in between the two stage decks (see fig. 05).
- 03) Connect both sets.
- 04) For the correct placement of the Mammoth Stage Self-leveling Insert, see pages 10-11.

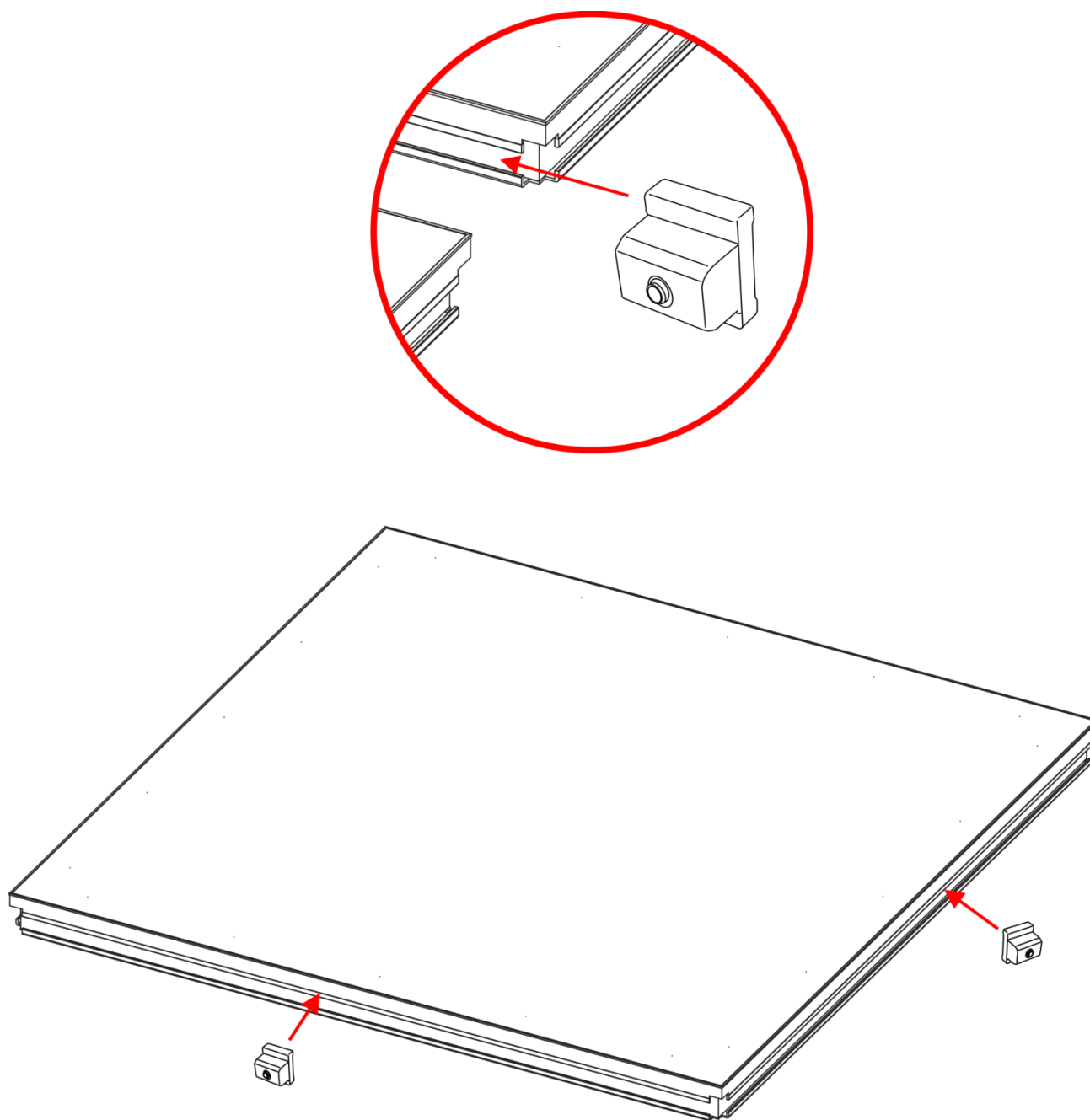

Fig. 05

### Installation Example

It is possible to attach multiple Mammoth Stage decks (**70610/70620**) to each other. In order to create more stability when connecting inner decks, use the Mammoth Stage clamps (**70630**) as presented below:

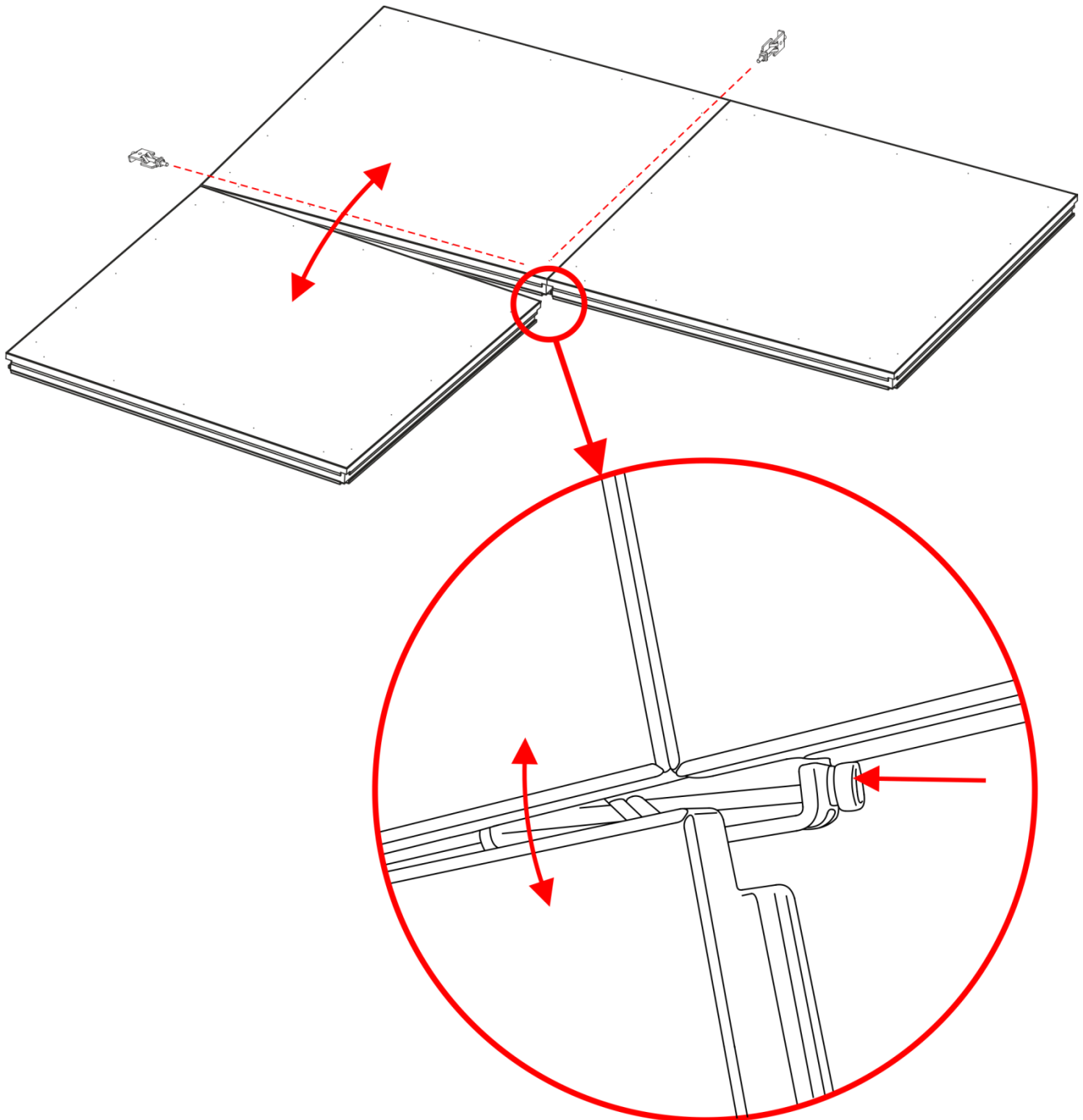

Fig. 06

- 01) In order to connect two inner decks, slightly pull them apart to create adequate space for inserting the Mammoth Stage clamp.
- 02) Loosen the screw to make the Mammoth Stage clamp more flexible.
- 03) Slide the Mammoth Stage clamp partially into the slot, to connect both Mammoth Stage decks.
- 04) Once you have succeeded, insert the Mammoth Stage clamp completely into the slot.
- 05) Tighten the screw.
- 06) In this way, the Mammoth Stage decks are fitted to each other not only on the outside but also on the inside of the installation, which adds to the overall stability.
- 07) For more details, see fig.07 and fig.08 on pages 10-11.

## Examples

### 12 m<sup>2</sup> Mammoth Stage

The list of needed items:

- **(A)** 12 x Mammoth Stage 1 x 1 m **(70610)**
- 12 x Mammoth Legs 20/40/60 cm (1 x 1 m) **(70611/70612/70613)**
- **(B)** 22 x Mammoth Stage Clamp **(70630)**
- **(C)** 14 x Mammoth Stage Self-leveling Insert **(70637)**
- **(D)** 1 x Mammoth Stairs 40/60 cm **(70633/70634)**
- 2 x Case for 6 x Mammoth Stage (1 x 1 m) **(D7225)**

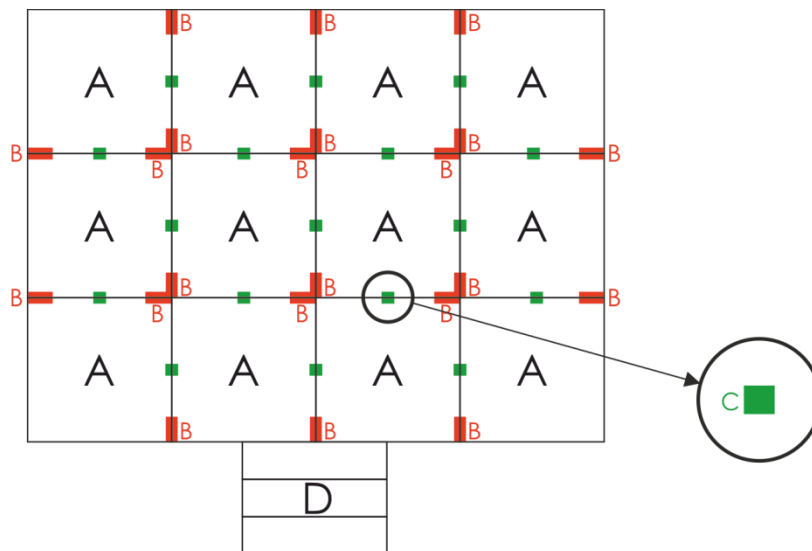

70630

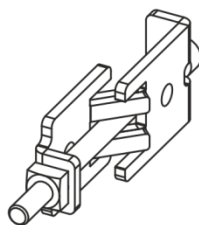

70637

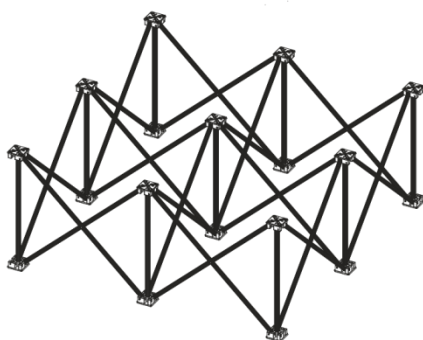
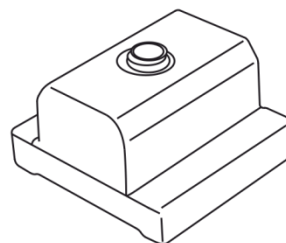

70611/70612/70613 (1 x 1 m)

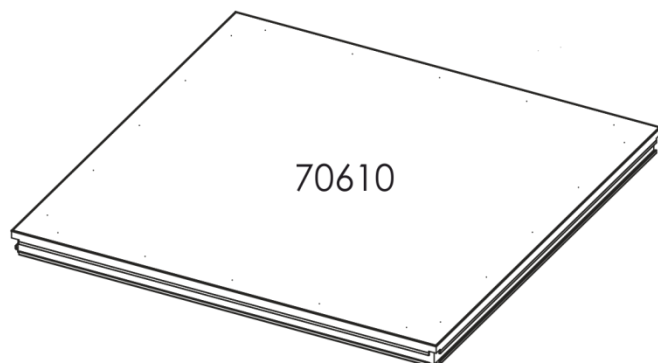

Fig. 07

## 60 m<sup>2</sup> Mammoth Stage

The list of needed items:

- **(A)** 30 x Mammoth Stage 2 x 1 m **(70620)**
- 60 x Mammoth Legs 20/40/60 cm (1 x 1 m) **(70611/70612/70613)**
- **(B)** 58 x Mammoth Stage Clamp **(70630)**
- **(C)** 49 x Mammoth Stage Self-leveling Insert **(70637)**
- **(D)** 1 x Mammoth Stairs 40/60 cm **(70633/70634)**
- **(E)** 22 x Mammoth Guard Rail (1 m) **(70631)**
- 44 x Mammoth Guard Rail Clamp **(70632)**

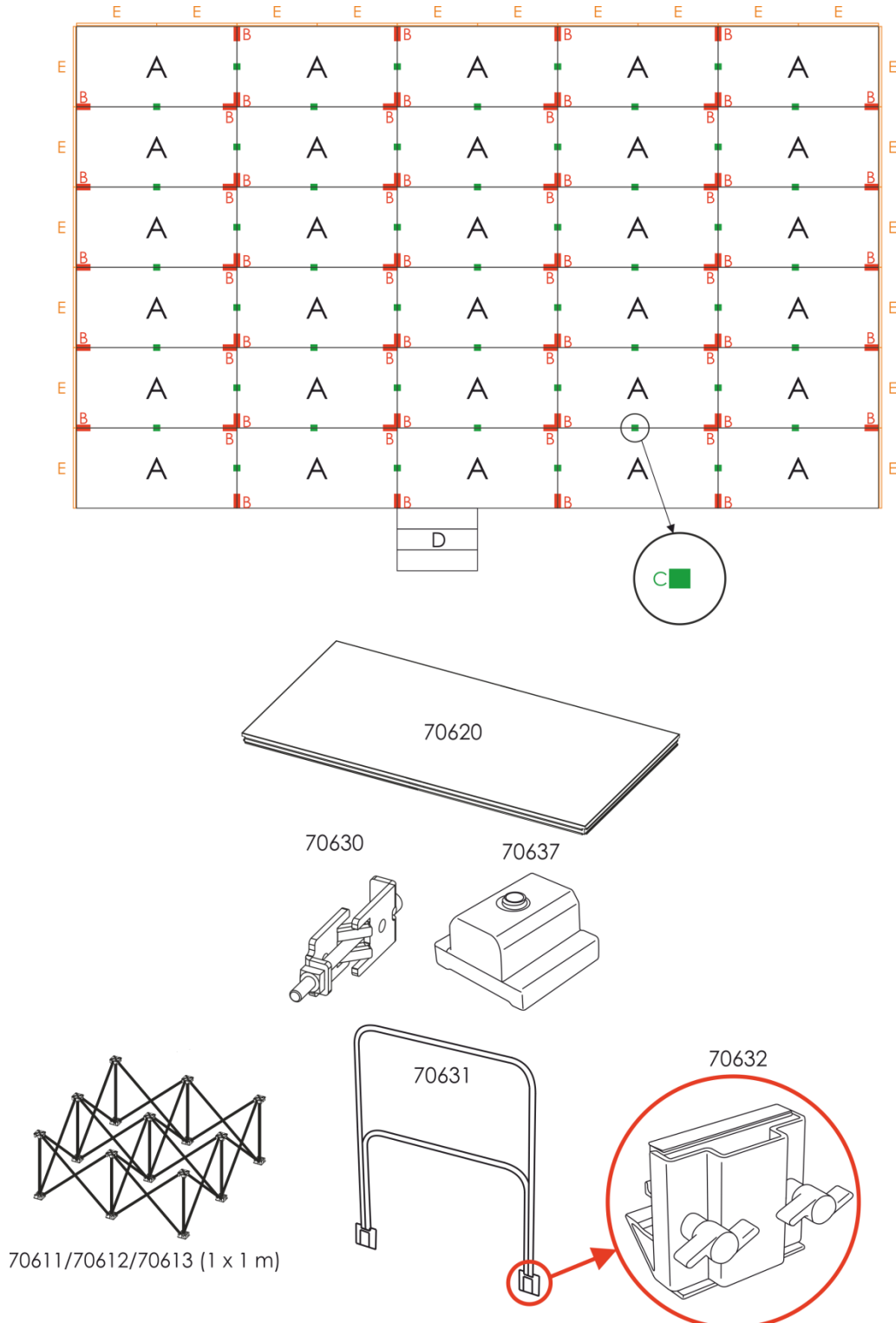

Fig. 08

## Miscellaneous

---

The Mammoth Stage comes in 2 heights: 40 cm and 60 cm.

### Total Height Information

#### Mammoth Stage (40 cm)

- Mammoth Stage Deck (**70610/70620**) + Mammoth Legs 40 cm (**70612**) = 415 mm
- Mammoth Stairs 20+40 cm (**70633**) = 400 mm

#### Mammoth Stage (60 cm)

- Mammoth Stage Deck (**70610/70620**) + Mammoth Legs 60 cm (**70613**) = 613 mm
- Mammoth Stairs 60 cm (**70613**) = 600 mm

## Maintenance

---

The user has to make sure that safety-related installations are to be inspected by an expert after every year in the course of an acceptance test.

The user has to make sure that safety-related installations are to be inspected by a skilled person once a year.

The following points have to be considered during the inspection:

- 01) All screws used for installing the device or parts of the device have to be tightly connected and must not be corroded.
- 02) There may not be any deformations on housings, fixations and installation spots.
- 03) Mechanically moving parts like axles, eyes and others may not show any traces of wearing.
- 04) The electric power supply cables must not show any damages or material fatigue.

## Product Specifications

Model:	Showgear Mammoth Stage 1 x 1 m / 2 x 1 m
Maximum load:	500 kg/m <sup>2</sup>
Material:	Aluminum (6063-T66)
Dimensions:	1000 x 1000 x 55 mm (LxWxH) / 2000 x 1000 x 55 mm (LxWxH)
Weight:	12 kg / 24 kg

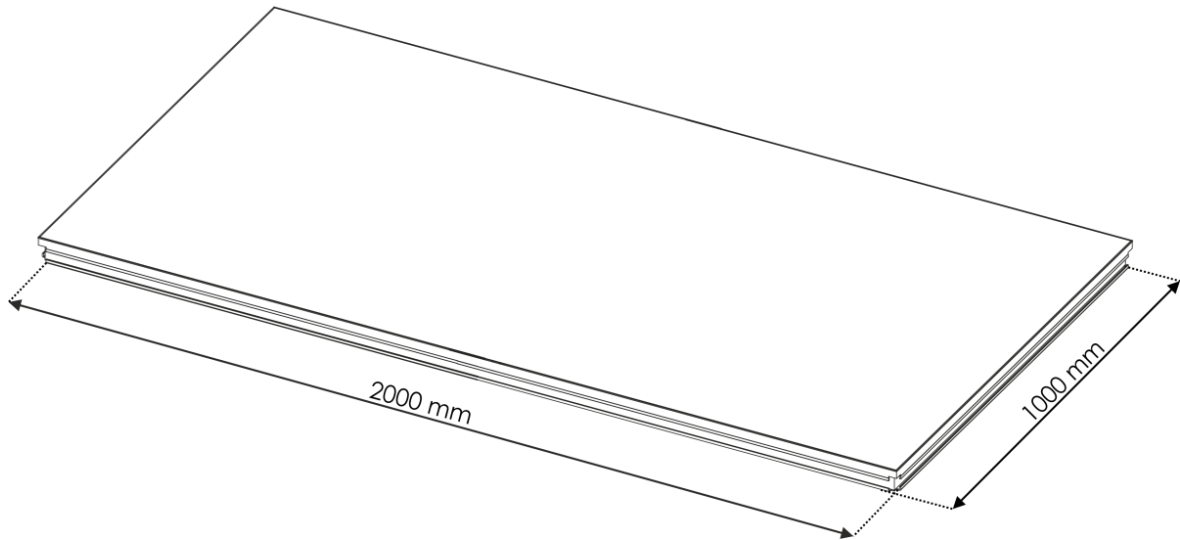
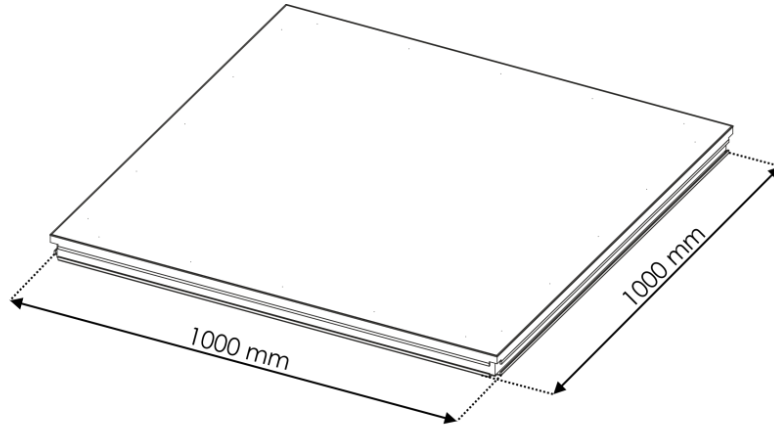

Design and product specifications are subject to change without prior notice.



Website: [www.Showgear.info](http://www.Showgear.info)  
Email: [service@highlite.com](mailto:service@highlite.com)



---

**SHOW  
GEAR**

©2021 Showgear