

**Kramer Electronics, Ltd.**



# **USER MANUAL**

**Model:**

**TBUS-3**

*Table Connection Bus*

## Contents

<b>1</b>	<b>Introduction</b>	<b>1</b>
<b>2</b>	<b>Getting Started</b>	<b>1</b>
2.1	Quick Start	2
<b>3</b>	<b>Overview</b>	<b>3</b>
<b>4</b>	<b>Your TBUS-3</b>	<b>4</b>
<b>5</b>	<b>Installing the TBUS-3 Table Connection Bus</b>	<b>6</b>
5.1	Cutting an Opening in the Table	6
5.2	Adjusting the Height of the Connecting Surface	7
5.3	Installing TBUS-3 in the Cut-Out Opening	7
5.4	Connecting the Cables	8
<b>6</b>	<b>Using the TBUS-3</b>	<b>9</b>
<b>7</b>	<b>Technical Specifications</b>	<b>10</b>

## Figures

Figure 1:	TBUS-3 Table Connection Bus	3
Figure 2:	TBUS-3 Table Connection Bus (Top View)	4
Figure 3:	TBUS-3 Connecting Surface	5
Figure 4:	Cutout Dimensions	6
Figure 5:	Installing TBUS-3	8
Figure 6:	Connecting the Cables	8
Figure 7:	TBUS-3 Boardroom Installation	9

## Tables

Table 1:	TBUS-3 Table Connection Bus Features	5
Table 2:	TBUS-3 Connecting Surface Features	6
Table 3:	TBUS-3 Technical Specifications	10

## 1 Introduction

Welcome to Kramer Electronics! Since 1981, Kramer Electronics has been providing a world of unique, creative, and affordable solutions to the vast range of problems that confront the video, audio, presentation, and broadcasting professional on a daily basis. In recent years, we have redesigned and upgraded most of our line, making the best even better! Our 1,000-plus different models now appear in 11 groups<sup>1</sup> that are clearly defined by function.

Thank you for purchasing the Kramer **TBUS-3** table connection bus, which is ideal for boardrooms, conference and training rooms!

The package includes the following items:

- **TBUS-3** *Table Connection Bus*
- 2 table clamps
- Power cord<sup>2</sup>
- 6 self-locking ties
- Cut-out template
- 4 screws for holding template
- This user manual<sup>3</sup>

## 2 Getting Started

We recommend that you:

- Unpack the equipment carefully and save the original box and packaging materials for possible future shipment
- Review the contents of this user manual
- Use Kramer high-performance, high-resolution cables<sup>4</sup>

---

1 GROUP 1: Distribution Amplifiers; GROUP 2: Switchers and Matrix Switchers; GROUP 3: Control Systems; GROUP 4: Format/Standards Converters; GROUP 5: Range Extenders and Repeaters; GROUP 6: Specialty AV Products; GROUP 7: Scan Converters and Sealers; GROUP 8: Cables and Connectors; GROUP 9: Room Connectivity; GROUP 10: Accessories and Rack Adapters; GROUP 11: Sierra Products

2 We recommend that you use only the power cord supplied with this device

3 Download up-to-date Kramer user manuals from our Web site: <http://www.kramerelectronics.com>

4 The complete list of Kramer cables is on our Web site at <http://www.kramerelectronics.com>

## 2.1 Quick Start

This quick start chart summarizes the basic setup and operation steps.

**Step 1: Cut an opening in the table - see section 5.1**

Cut out an opening in your table using the cutout template

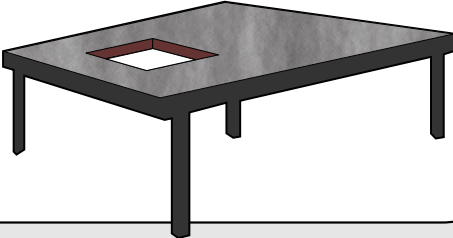

**Step 2: Adjust the height of the connecting surface - see section 5.2**

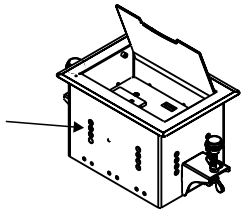

**Step 3: Remove the rubber guard and insert the unit - see section 5.3**

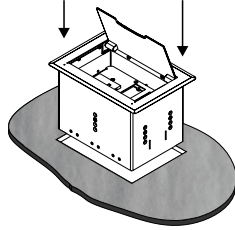

**Step 4: Secure the unit to the table - see section 5.3**

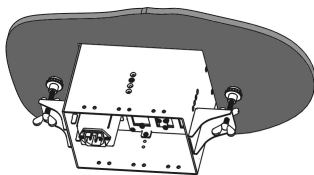

**Step 5: Connect the cables - see section 5.4**

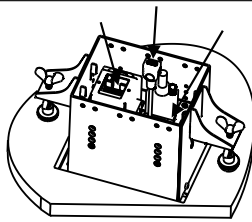

### 3 Overview

The Kramer **TBUS-3** is a high-quality, anodized aluminum, table-mounted connection bus for boardrooms and conference rooms. Its attractive enclosure is designed to provide maximum connectivity in the smallest possible footprint. The unit is sturdy, cost-effective, and easy to install.

**TBUS-3** includes:

- Four permanent components suitable for connecting a PC: one 15-pin HD (F) connector, one Ethernet connector, one stereo audio 3.5mm mini jack, and one USB-A connector
- One power socket - available in 7 versions: USA, UK, Germany-EU, Belgium-France, South Africa, Australia, and “Universal” (for use anywhere<sup>1</sup>)

**TBUS-3** is height-adjustable and the cover opens and closes manually, keeping the cables and the connectors out of sight when not used.

To achieve the best performance:

- Use only good quality connection cables<sup>2</sup> to avoid interference, deterioration in signal quality due to poor matching, and elevated noise levels (often associated with low quality cables)
- Avoid interference from neighboring electrical appliances that may adversely influence signal quality
- Position **TBUS-3** away from moisture, excessive sunlight, and dust



*Figure 1: TBUS-3 Table Connection Bus*

---

<sup>1</sup> See compatibility restrictions in the Specification section [7](#)

<sup>2</sup> Available from Kramer Electronics on our Web site at <http://www.kramerelectronics.com>



Beware of sharp edges on the inner and outer rim of the mounting plate and on the lid of **TBUS-3**. They can cause serious injury.

Do not place heavy objects on top of the **TBUS-3**.

#### 4 Your TBUS-3

[Figure 2](#) and [Table 1](#) define the unit.

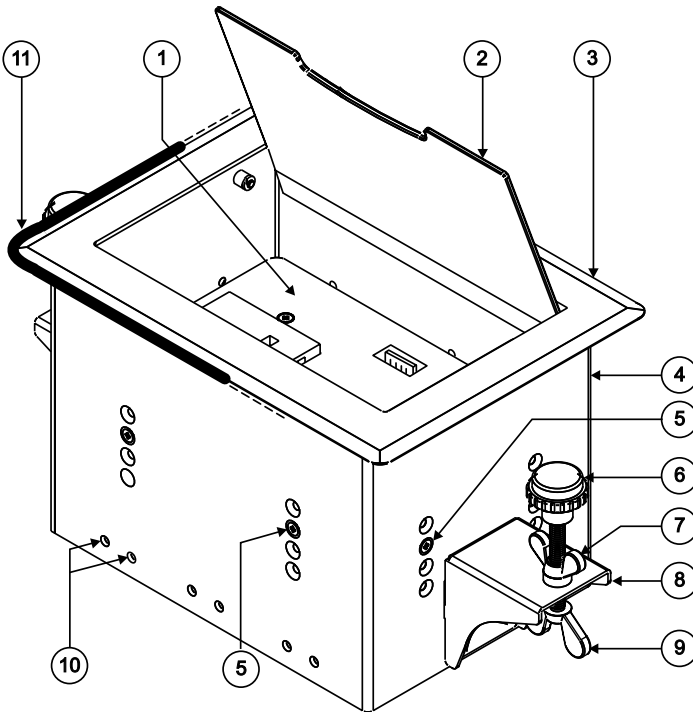

*Figure 2: TBUS-3 Table Connection Bus (Top View)*

Table 1: TBUS-3 Table Connection Bus Features

#	Feature	Function
1	Connecting Surface	See <a href="#">Figure 3</a> and <a href="#">Table 2</a>
2	Black Anodized Lid	Covers the connecting surface, leaving the table surface neat and tidy
3	Mounting Plate Outer Rim	Fits over the table surface
4	Enclosure	Inserts into the table cutout
5	Height Adjustment Screws	Eight screws for adjusting the height of the connecting surface, two on each panel
6	Rubber Protectors	Protect the table surface when mounting the unit (one on each side)
7	Locking Butterfly Screws	Tighten to lock the mounting butterfly screw (one on each side)
8	Mounting Brackets	Fit in the bracket slits after inserting the enclosure into the table – to secure the unit to the table surface (one on each side)
9	Mounting Butterfly Screws	Tighten to secure the unit to the table surface (one on each side)
10	Tie Holes <sup>1</sup>	Anchor the self-locking ties to secure the pass-through cables to the inside walls of the unit (6 pairs of holes, 3 pairs on the front and 3 pairs on the rear panel)
11	Protective Rubber Guard	Protects the mounting plate outer rim during shipping. Remove before installing unit

[Figure 3](#) and [Table 2](#) define the connecting surface:

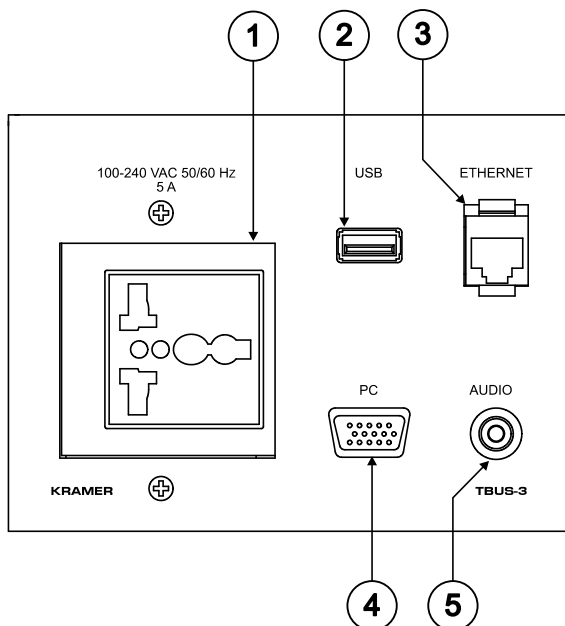

Figure 3: TBUS-3 Connecting Surface

<sup>1</sup> Some versions may not include tie holes

Table 2: TBUS-3 Connecting Surface Features

#	Feature	Function
1	Power Socket	Power socket for PC
2	USB connector	USB-A (female / female)
3	Ethernet connector	RJ-45 (female / female)
4	PC connector	Computer graphics 15-pin HD (female / female)
5	Audio connector	3.5mm stereo audio (female / female)

## 5 Installing the TBUS-3 Table Connection Bus

To install **TBUS-3**, perform the following steps:

1. Cut an opening in the table (see section [5.1](#)).
2. Adjust the height of the connecting surface (see section [5.2](#)).
3. Install **TBUS-3** in the cut-out opening (see section [5.3](#)).
4. Connect the cables (see section [5.4](#)).

### 5.1 Cutting an Opening in the Table

To cut an opening in the table:

1. Place the included cut-out template on the surface of the table where you want to install **TBUS-3**.
2. Attach the template to the table with the included screws.
3. Following the inside edge of the template, cut a hole in the table surface with a sabre or keyhole saw according to the dimensions shown in [Figure 4](#) (not to scale).

**Note:** The thickness of the table should be 3 inches or less.

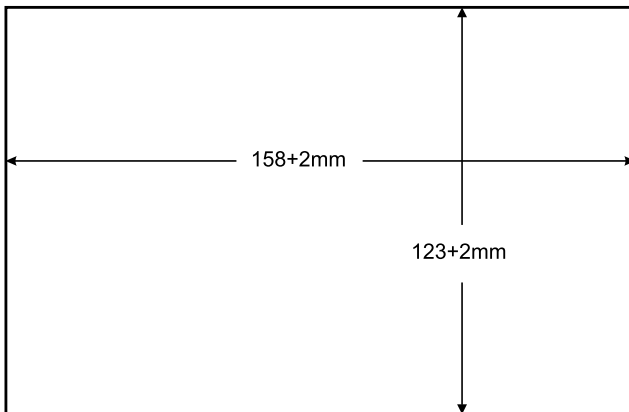

Figure 4: Cutout Dimensions



4. Unscrew and remove the template from the surface of the table and clean the table surface.  
Take care not to damage the table.  
If needed, you can download a full-scale template from our Web site<sup>1</sup>.

Kramer Electronics is not responsible for any damage caused to the table

## 5.2 Adjusting the Height of the Connecting Surface

If needed, you can adjust the connecting surface to one of four possible heights to accommodate large or bulky cables. By default, the height is set to the second level from the top. To adjust, perform the following:

1. Remove the eight height adjustment screws (two screws on each side, as shown in [Figure 2](#)), while supporting the surface from underneath with your fingers.
2. Raise or lower the connecting surface to the required height, insert the screws, and tighten them in place.

## 5.3 Installing TBUS-3 in the Cut-Out Opening

To install **TBUS-3** in the opening:

1. Remove the protective rubber guard from around the outer rim of the mounting plate. **Beware of the sharp edge!**
2. Carefully insert the unit into the prepared opening (see [Figure 5](#)).
3. Take the support brackets under the table and place them into the support bracket grooves on both sides of the unit (see [Figure 2](#)).
4. Verify proper alignment of the unit before tightening the mounting screws.
5. Screw both mounting butterfly screws upward until they reach the table surface (from underneath). Tighten firmly (see [Figure 5](#)).
6. Screw the locking butterfly screws downward until tight against the mounting bracket.

---

<sup>1</sup> At <http://www.kramerelectronics.com>

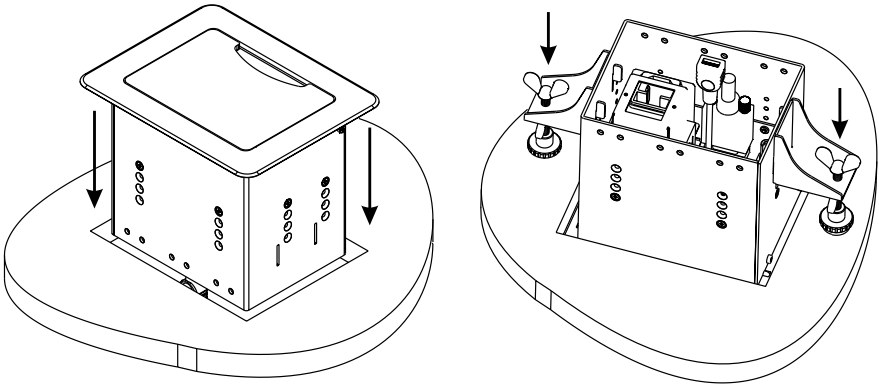

*Figure 5: Installing TBUS-3*

## 5.4 Connecting the Cables

To connect the cables:

1. Insert the cables to their appropriate connectors from underneath.
2. Secure the cables to the tie holes using the included self-locking ties.  
Do not secure the cables too tightly or too loosely. Leave a small amount of slack.

After the unit is connected to mains power and the proper cables, it is ready for use.

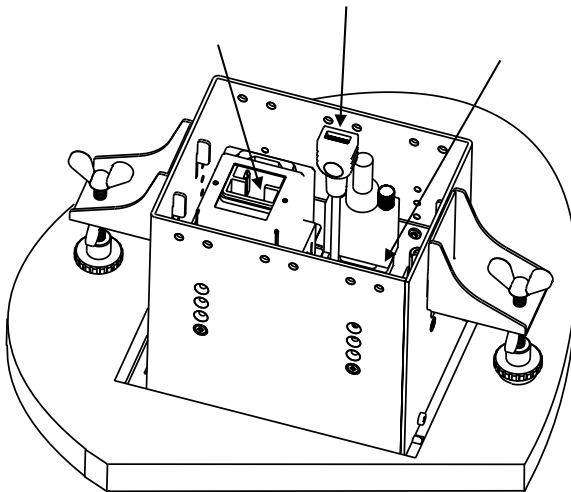

*Figure 6: Connecting the Cables*

## 6 Using the TBUS-3

Once the **TBUS-3** is installed, you can easily customize it to your own needs by plugging in the desired A/V equipment, as illustrated in the example in [Figure 7](#).

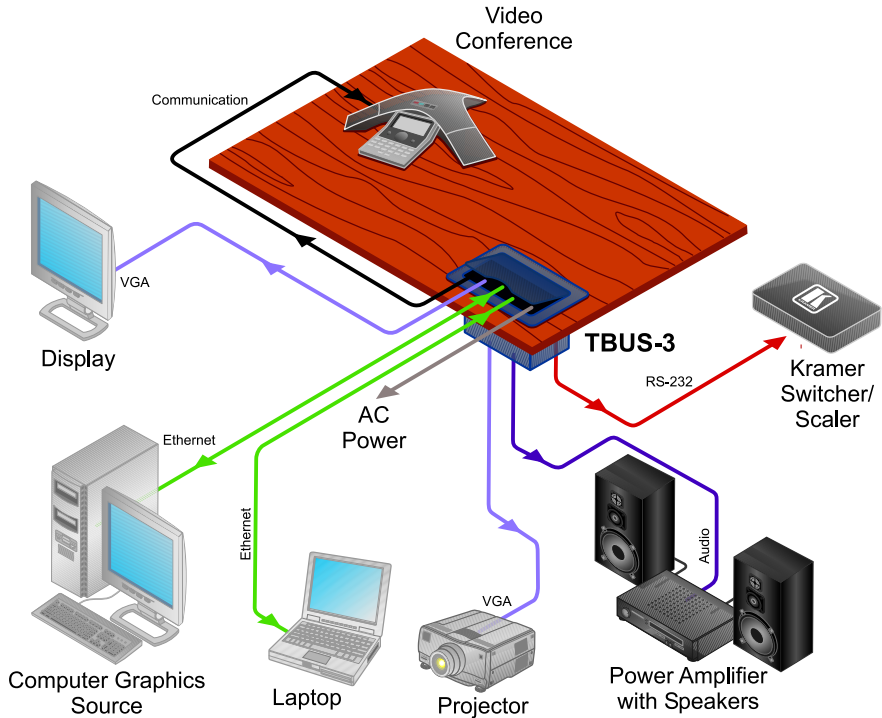

*Figure 7: TBUS-3 Boardroom Installation*

## 7 Technical Specifications

TBUS-3 technical specifications are shown in [Table 3](#):

*Table 3: TBUS-3 Technical Specifications<sup>1</sup>*

POWER SOURCE (AC power limits):	Universal <sup>2, 3, 4</sup>	100-240V AC, 50/60Hz, 5A
	USA	100-240V AC, 50/60Hz, 5A
	UK	100-240V AC, 50/60Hz, 5A
	Germany and EU	100-240V AC, 50/60Hz, 5A
	Belgium and France	100-240V AC, 50/60Hz, 5A
	South Africa	100-240V AC, 50/60Hz, 5A
	Australia	100-240V AC, 50/60Hz, 5A
FUSE RATING:	T 6.3A 250V	
OPERATING TEMPERATURE RANGE:	+5 to +45Deg. C	
OPERATING HUMIDITY RANGE:	10 to 90% RHL, non-condensing	
STORAGE TEMPERATURE RANGE:	-20 to +70Deg. C	
STORAGE HUMIDITY RANGE:	5 to 95% RHL, non-condensing	
DIMENSIONS:	Top plate: 176mm x 140.4mm (6.9" x 5.5") W, D Enclosure: 136mm x 102mm x 130mm (5.4" x 4.0" x 5.1") W, D, H	
WEIGHT:	TBUS-3: 1.02kg (2.25lb) approx. Table clamps: 0.257kg (0.566lbs) Template: 0.125kg (0.275lbs)	
ACCESSORIES:	Power cord, table clamps, self locking ties, template, template screws	

<sup>1</sup> Specifications are subject to change without notice

<sup>2</sup> The Universal socket is fully compatible with power plugs in UK, India, Italy, Denmark and the 2-prong Europlug

<sup>3</sup> The Universal socket is partially compatible (polarity is reversed) with plugs in China, Switzerland, Israel and USA. The Universal socket does not supply grounding to plugs in Central Europe and France. Order country specific sockets instead

<sup>4</sup> The Universal socket does not fit South African plugs

---

## LIMITED WARRANTY

Kramer Electronics (hereafter *Kramer*) warrants this product free from defects in material and workmanship under the following terms.

### HOW LONG IS THE WARRANTY

Labor and parts are warranted for seven years from the date of the first customer purchase.

### WHO IS PROTECTED?

Only the first purchase customer may enforce this warranty.

### WHAT IS COVERED AND WHAT IS NOT COVERED

Except as below, this warranty covers all defects in material or workmanship in this product. The following are not covered by the warranty:

1. Any product which is not distributed by Kramer, or which is not purchased from an authorized Kramer dealer. If you are uncertain as to whether a dealer is authorized, please contact Kramer at one of the agents listed in the Web site [www.kramerelectronics.com](http://www.kramerelectronics.com).
2. Any product, on which the serial number has been defaced, modified or removed, or on which the WARRANTY VOID IF TAMPERED sticker has been torn, reattached, removed or otherwise interfered with.
3. Damage, deterioration or malfunction resulting from:
  - i) Accident, misuse, abuse, neglect, fire, water, lightning or other acts of nature
  - ii) Product modification, or failure to follow instructions supplied with the product
  - iii) Repair or attempted repair by anyone not authorized by Kramer
  - iv) Any shipment of the product (claims must be presented to the carrier)
  - v) Removal or installation of the product
  - vi) Any other cause, which does not relate to a product defect
  - vii) Cartons, equipment enclosures, cables or accessories used in conjunction with the product

### WHAT WE WILL PAY FOR AND WHAT WE WILL NOT PAY FOR

We will pay labor and material expenses for covered items. We will not pay for the following:

1. Removal or installations charges.
2. Costs of initial technical adjustments (set-up), including adjustment of user controls or programming. These costs are the responsibility of the Kramer dealer from whom the product was purchased.
3. Shipping charges.

### HOW YOU CAN GET WARRANTY SERVICE

1. To obtain service on you product, you must take or ship it prepaid to any authorized Kramer service center.
2. Whenever warranty service is required, the original dated invoice (or a copy) must be presented as proof of warranty coverage, and should be included in any shipment of the product. Please also include in any mailing a contact name, company, address, and a description of the problem(s).
3. For the name of the nearest Kramer authorized service center, consult your authorized dealer.

### LIMITATION OF IMPLIED WARRANTIES

All implied warranties, including warranties of merchantability and fitness for a particular purpose, are limited in duration to the length of this warranty.

### EXCLUSION OF DAMAGES

The liability of Kramer for any effective products is limited to the repair or replacement of the product at our option. Kramer shall not be liable for:

1. Damage to other property caused by defects in this product, damages based upon inconvenience, loss of use of the product, loss of time, commercial loss; or:
2. Any other damages, whether incidental, consequential or otherwise. Some countries may not allow limitations on how long an implied warranty lasts and/or do not allow the exclusion or limitation of incidental or consequential damages, so the above limitations and exclusions may not apply to you.

This warranty gives you specific legal rights, and you may also have other rights, which vary from place to place.

**NOTE:** All products returned to Kramer for service must have prior approval. This may be obtained from your dealer.

This equipment has been tested to determine compliance with the requirements of:

- EN-50081: "Electromagnetic compatibility (EMC);  
generic emission standard.  
Part 1: Residential, commercial and light industry"
- EN-50082: "Electromagnetic compatibility (EMC) generic immunity standard.  
Part 1: Residential, commercial and light industry environment".
- CFR-47: FCC\* Rules and Regulations:  
Part 15: "Radio frequency devices  
Subpart B Unintentional radiators"

### CAUTION!

- Servicing the machines can only be done by an authorized Kramer technician. Any user who makes changes or modifications to the unit without the expressed approval of the manufacturer will void user authority to operate the equipment.
  - Use the supplied DC power supply to feed power to the machine.
  - Please use recommended interconnection cables to connect the machine to other components.
- \* FCC and CE approved using STP cable (fortwisted pair products)





---

**For the latest information on our products and a list of Kramer distributors, visit our Web site: [www.kramerelectronics.com](http://www.kramerelectronics.com) where updates to this user manual may be found.  
We welcome your questions, comments and feedback.**



**Caution**

**Safety Warning:**

Disconnect the unit from the power supply before opening/servicing.



---

**Kramer Electronics, Ltd.**

Web site: [www.kramerelectronics.com](http://www.kramerelectronics.com)

E-mail: [info@kramerelect.com](mailto:info@kramerelect.com)

**P/N: 2900-000339 REV 4**